

RTLS Architectures in Theory and Practice

Albrecht Rommel
Rainer Hach

October 21st, 2009
Wireless Congress, Munich

Overview / Agenda

- RTLS Application Fields
- Known Baseline Techniques
- RTLS Architectures
- Dominant Techniques
- TOA / TOF Techniques
 - Measurement Results
- TDOA Techniques
 - Measurement Results
- Improving accuracy

Application fields

- Real Time Locating Systems are used in many fields
 - Maritime navigation (Loran C, GPS)
 - Traffic navigation (GPS)
 - Military (Radar, Loran C, GPS)
 - Logistics (Container/asset tracking)
 - Social networking
 - Electronic fencing
 - Loss protection systems
 - Car finder
 - Medical/personal monitoring

Some known baseline techniques

- RF based
 - Time of Arrival (TOA)
 - Angle of Arrival (AOA)
 - Cell identification
 - RSSI (Received Signal Strength Indication) based distance estimation
 - Low frequency, near field phase evaluation
- Light (laser)
- (Ultra) sound

RTLS architectures

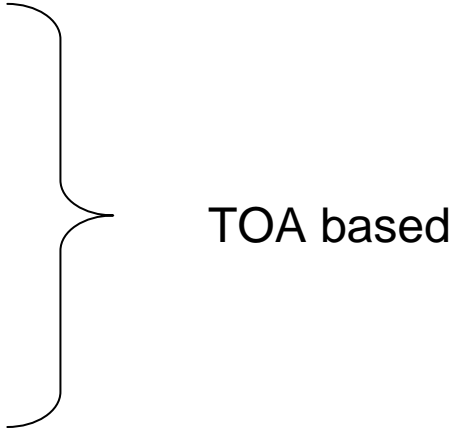
- RSSI with fixed infrastructure after site survey (calibration)
 - AOA at infrastructure
 - TOF with fixed infrastructure
 - TOF without fixed infrastructure
 - Peer to peer ranging, Moving mesh, platoon, group
 - TDOA at infrastructure nodes
 - TDOA at tag, (GPS like)
- 
- TOA based
- Hybrid systems

Dominant techniques

- RSSI
 - Issues: RSSI depends on many parameters, distance being only one among others

- Time Of Arrival
 - Time Of Flight (Distance Measurement)
 - Time Difference Of Arrival (Distance Difference Measurement)
 - Issues: TOA is effected by multi-path delay.

RF-based TOA Technology

ISO/IEC 24730-5 2.4 GHz CSS Air Interface

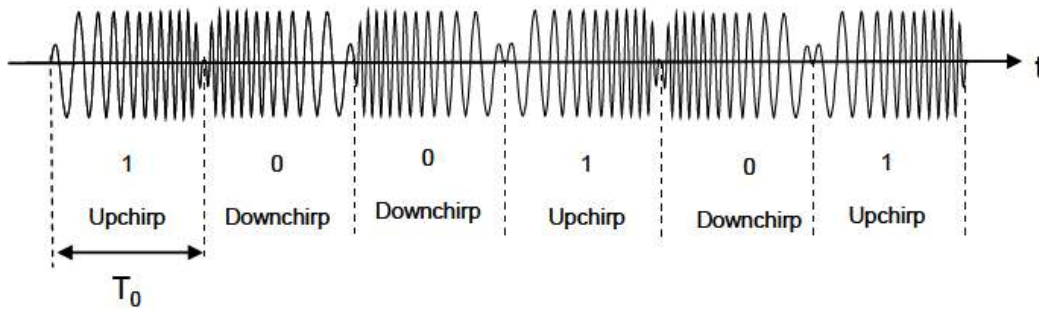

Figure 10 – 2-ary orthogonal CSS modulated bit sequence in passband domain

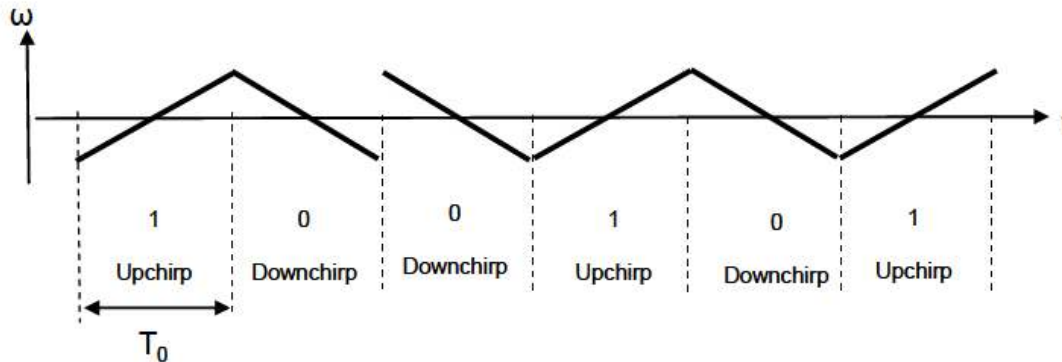

Figure 11 – 2-ary orthogonal CSS modulated bit sequence in time frequency domain

- Bandwidth
 - **80** (22) MHz
- Data rate
 - **1000** (250) kbit/s

24730-5 Physical Layer

2-ary Orthogonal CSS Receiver

- Up-Chirp and Down-Chirp are orthogonal and easy to separate

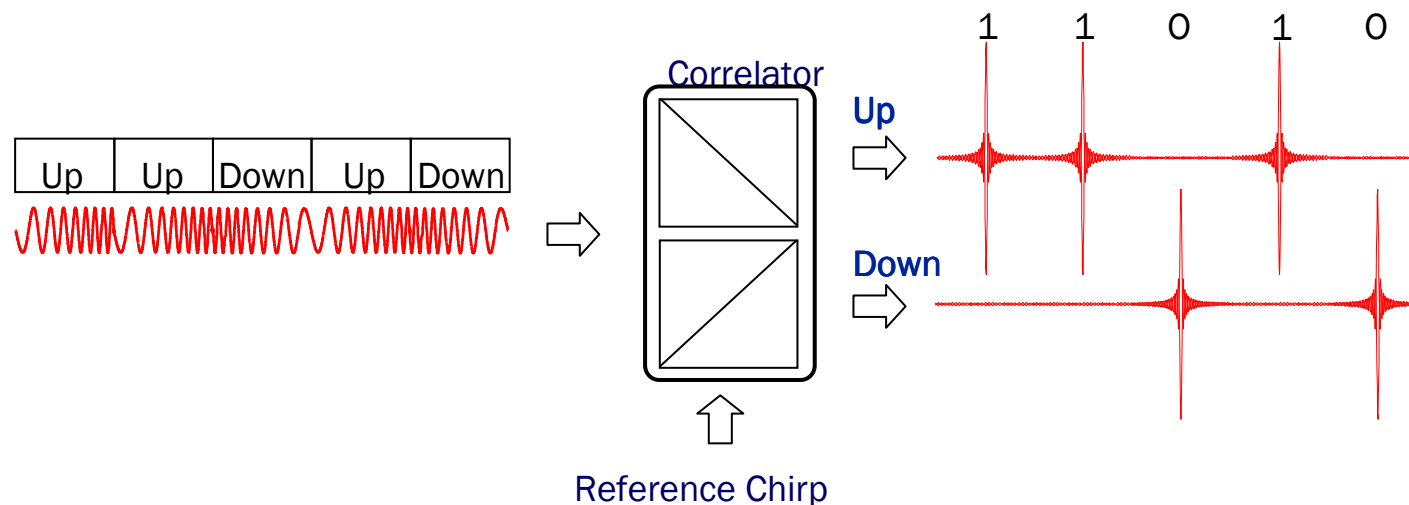

- Ranging and Localization: Simple and precise TOA (Time of Arrival) evaluation

RTLS Applications

Ranging (Distance) and Locating (Free-Form)

One Anchor:

Circular Virtual Safety Zone

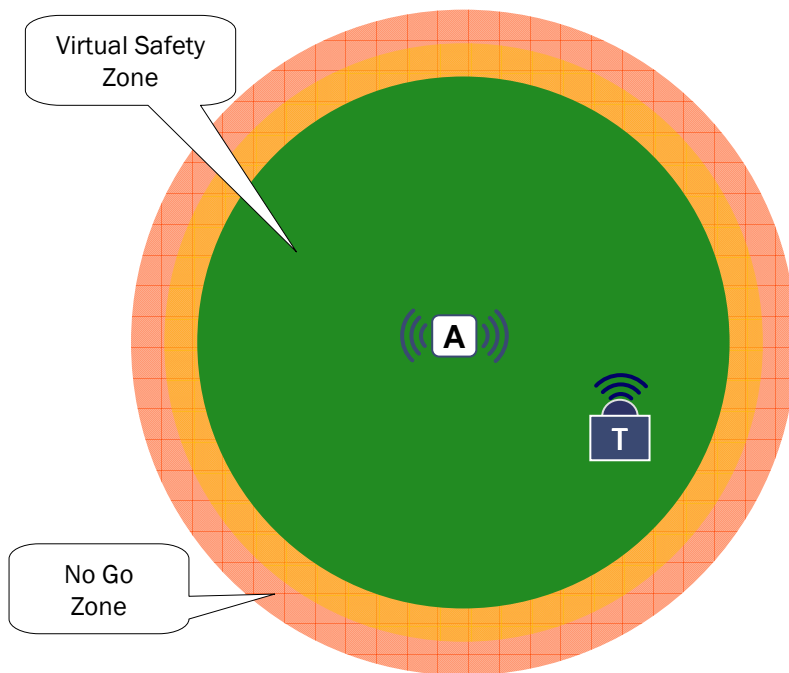

Multiple Anchors:

Free Form Virtual Safety Zone

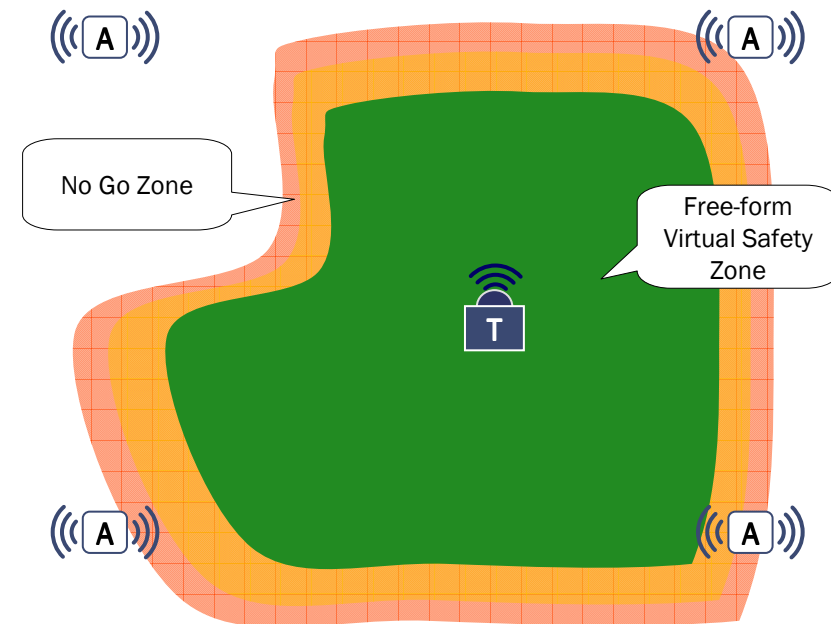

 Anchor Node

 Mobile Node or Tag

TOF between two Nodes

Example: Child Loss Protection (CLOPS)

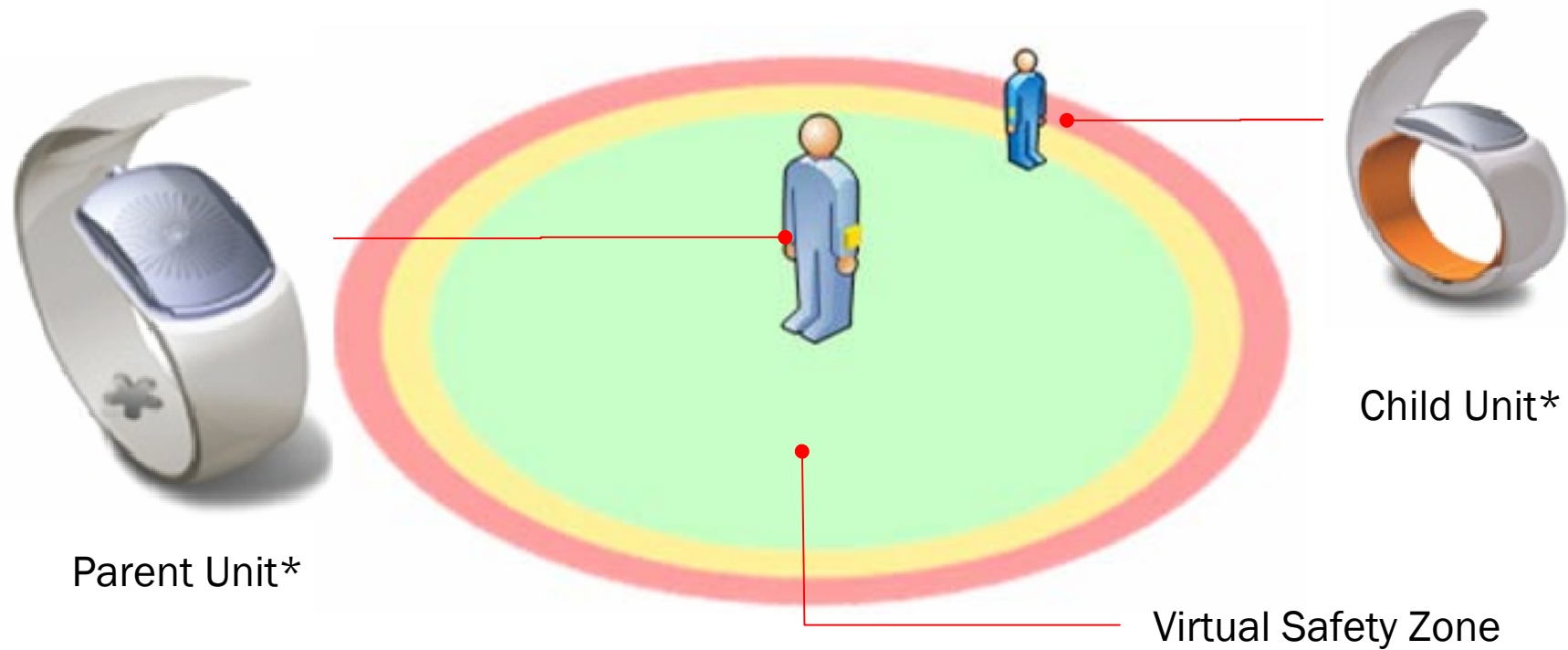

* Courtesy of DContinuum www.tuvie.com

TOF- Outdoor

Measurement Results - Ranging

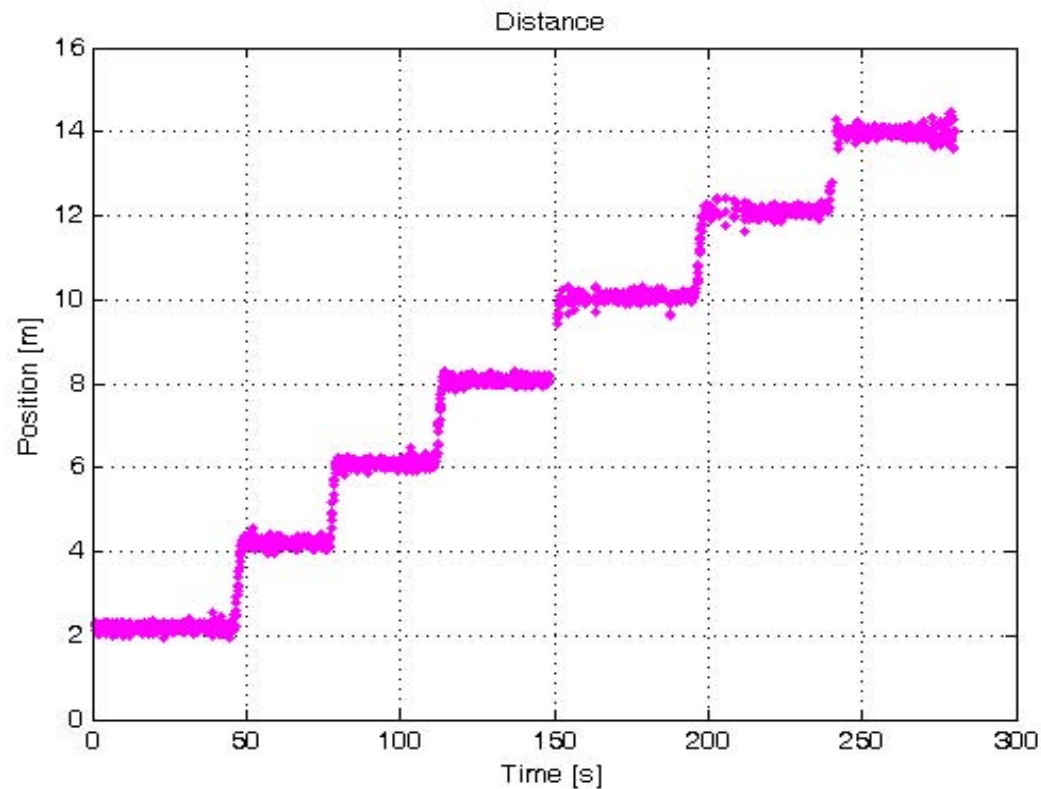

- Raw data
- Ranging mean value accuracy within a few cm
- Ranging Variance less than ± 20 cm

TOF Ranging Accuracy – Indoor

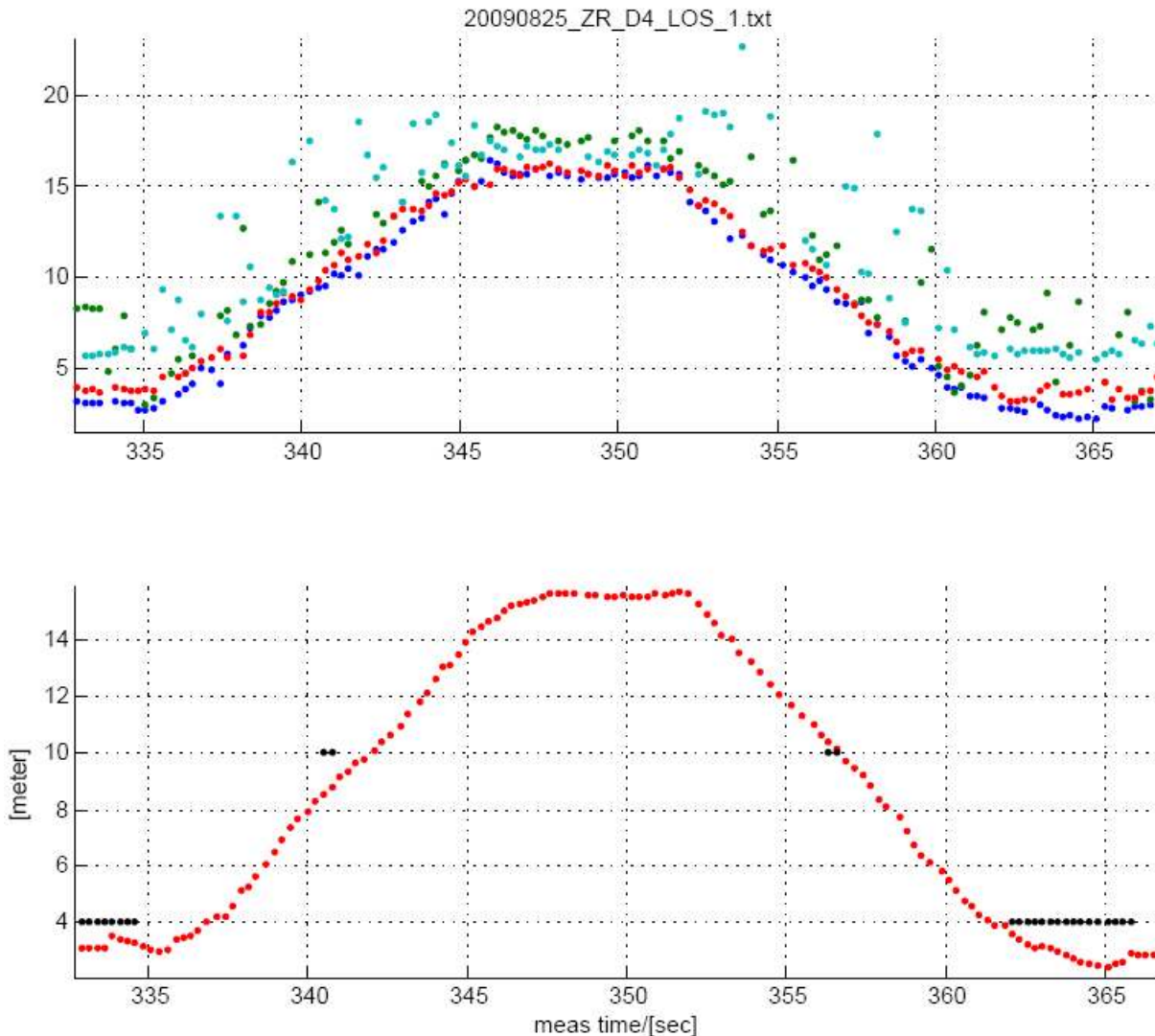

Measurement Results – Antenna Diversity

- Raw Data
- 4 Antennas

- Filtered Data
- Antenna Diversity selects shortest of 4 results

TOF Architectures

TOA/TOF-based RTLS with fixed Infrastructure

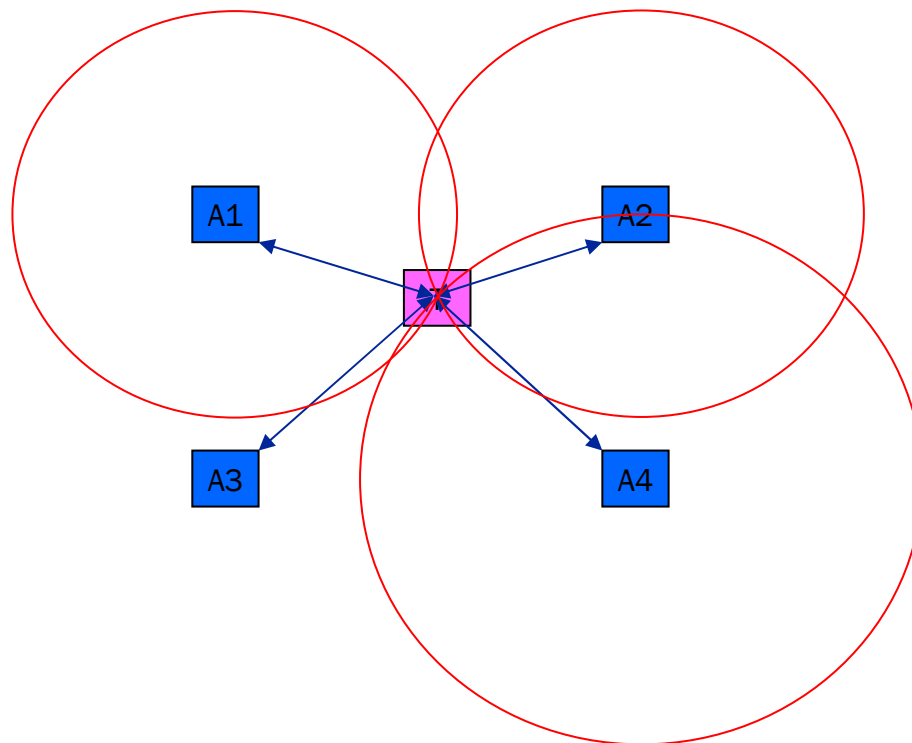

- Distance measurement between Anchors and Tag
- Tag position is calculated by trilateration
- PRO:
no synchronization infrastructure required
- CON:
only sequential distance measurements possible, limited number of measurements per time interval.

Measurement Results

TOF Outdoor – Raw Data

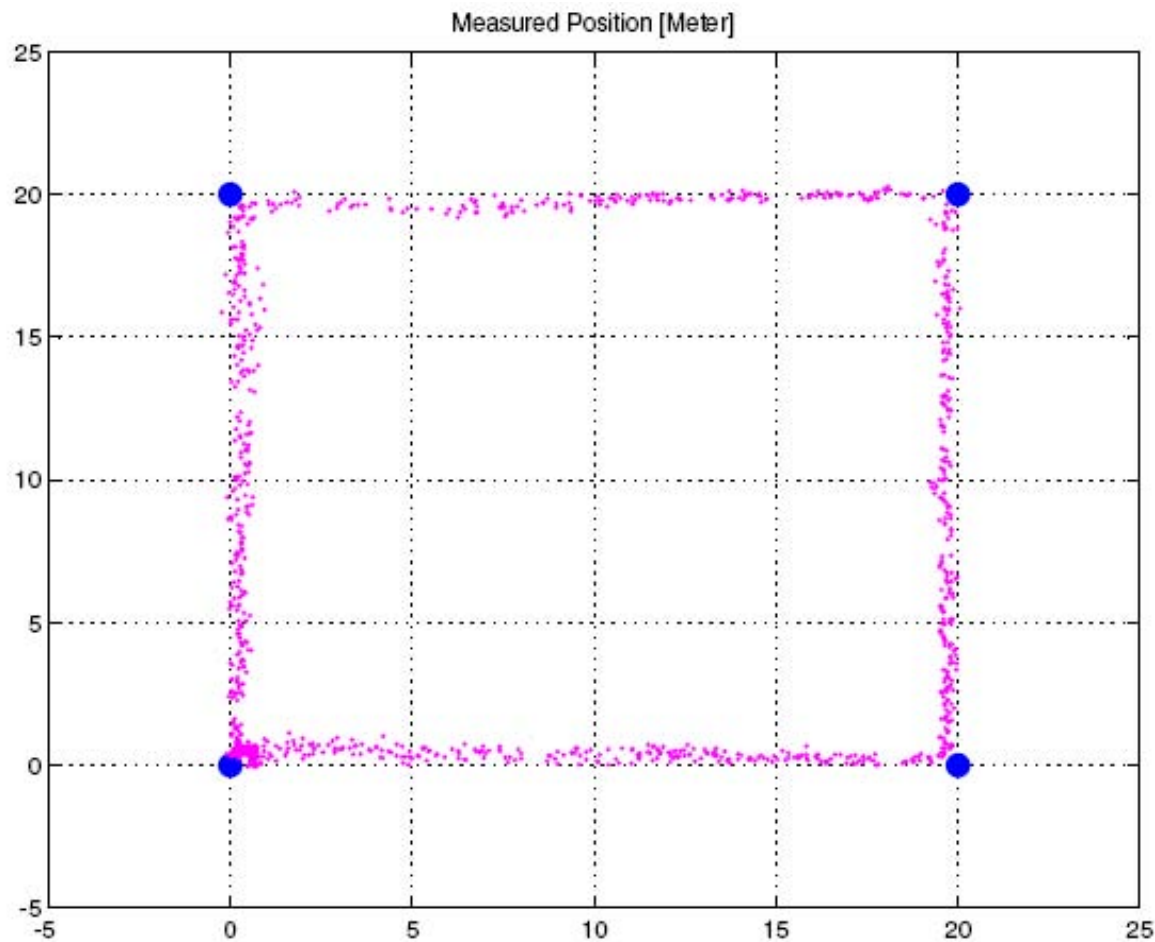

- Area 20 x 20 m
- walking from anchor to anchor
- Multipath-free environment
- Accuracy better than 0.5m

Measurement Results

TOF Outdoor – Filtered Data

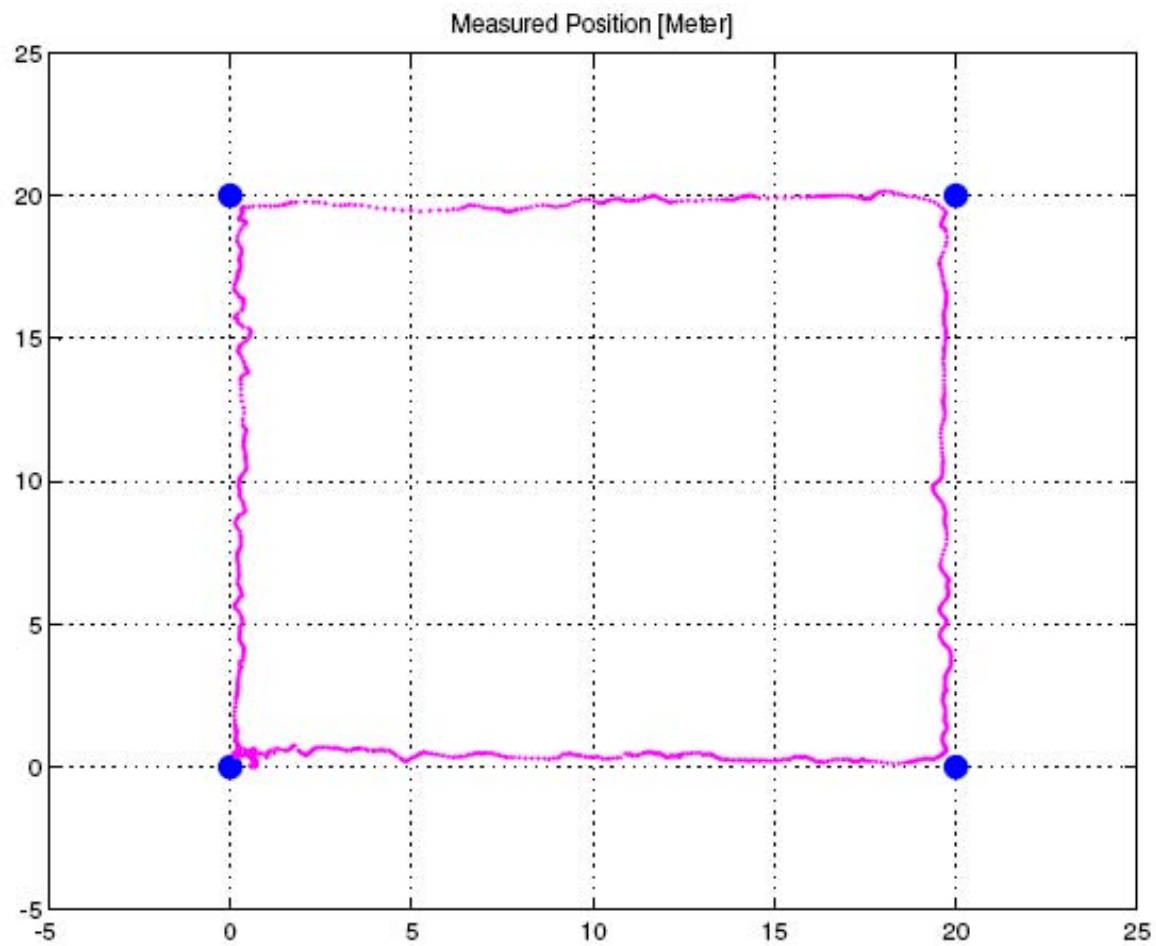

- Moving Average #11
- Accuracy in cm-range

Measurement Results - TOF Indoor

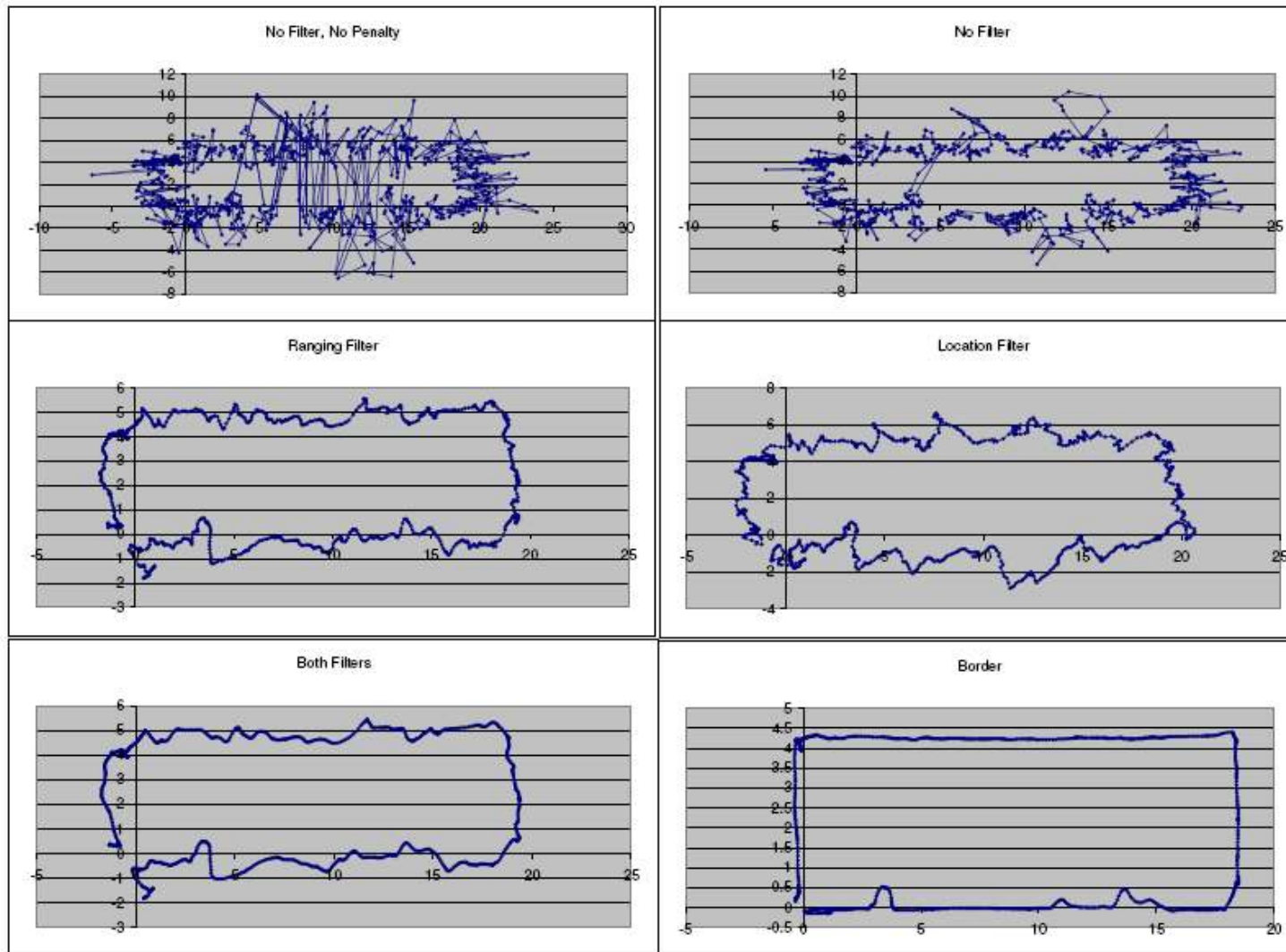

- Area 4.3 x 18 m
- Walking from corner to corner
- Heavy Multipath Environment
- Multiple Filter Options:
 - Plausibility constraint
 - Ranging filter
 - Location filter
 - Ranging/location combined
 - Border penalty

TDOA Architectures

TDOA at Infrastructure Nodes

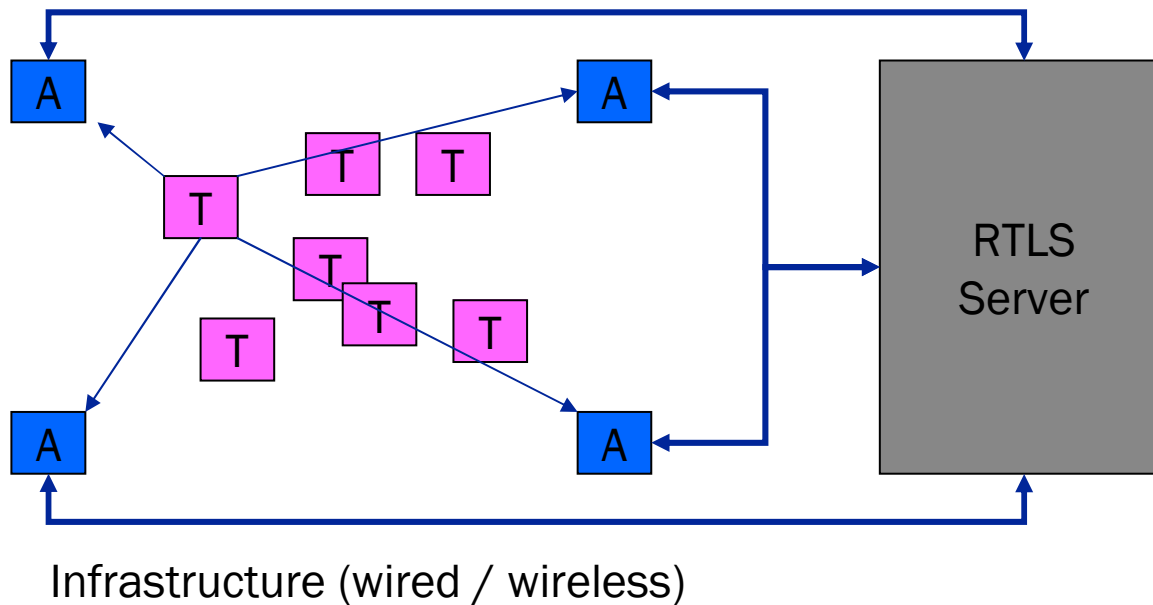

Anchor



Tag (up to x 1000's)

- Tags send broadcast blinks
- Anchors measure TOA of tag blinks
- RTLS server collects TOA measurements to calculate TDOA between anchor pairs
- PRO: Simultaneous reception of tag blinks by all anchors, high number of measurements per time interval
- CON: Anchors require Synchronization or very stable (atomic) clocks

TDOA Architectures

TDOA at Tags

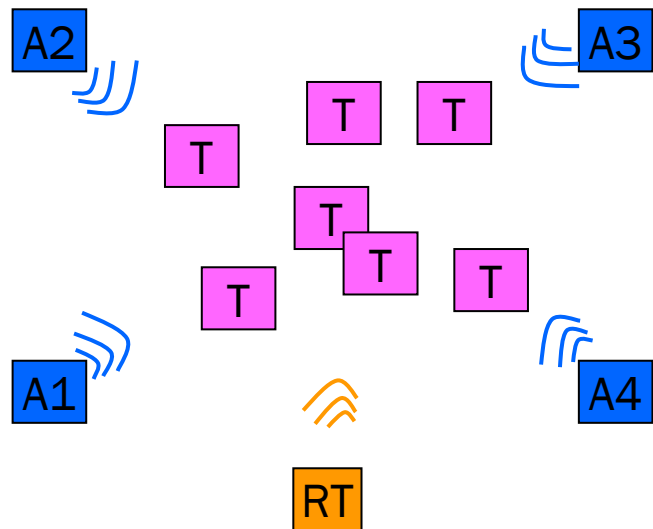

- A Anchor (known location)
- T Tags (unlimited #)
- RT Reference Transceiver (known location)

- Anchors send broadcast blinks
- Anchor blinks received by tags and RT
- RT sends TOAs of anchor blinks to tags
- Tags calculate TDOA between Tag and RT TOAs (Tag time base unknown!)
- Over-determined system
 - 4 anchors, 4 TDOA pairs ($TOA_{RT} - TOA_{Tag}$)
 - 3 unknowns (Tag x,y,time)
- PRO:
 - unlimited number of tags, only 5 transmitting devices (A1-A4, RT)
- CON:
 - Anchors and RT require Synchronization or very stable (atomic) clocks

TDOA Architectures

TDOA Location Calculation, Hyperbolas

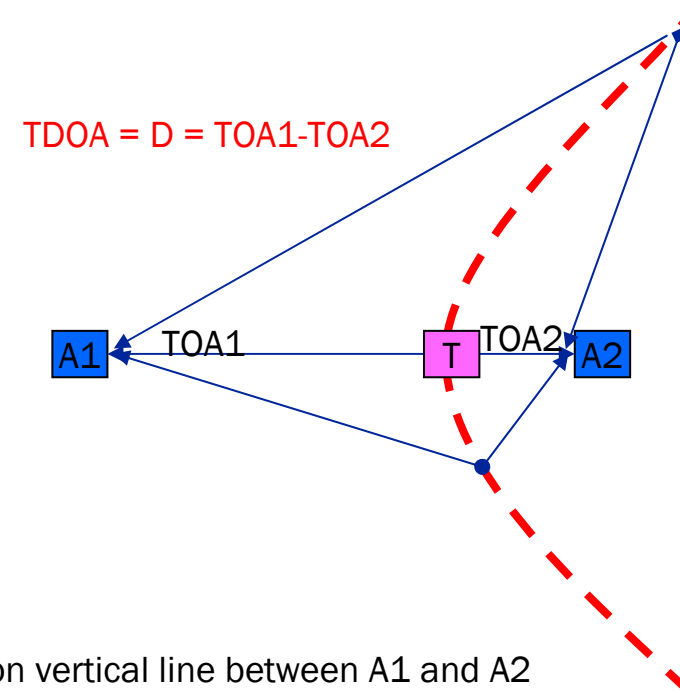
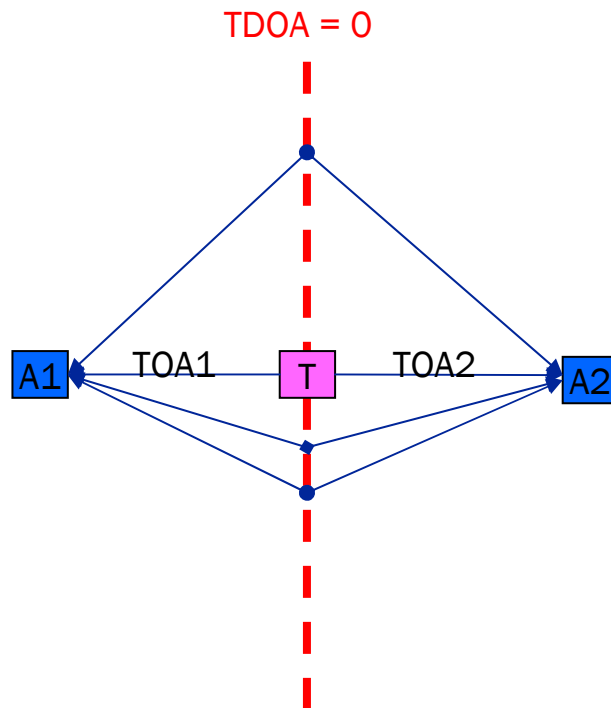

- TDOA=0: Tag is on vertical line between A1 and A2
- TDOA = D:
Tag is on Hyperbola between A1 and A2
- 2D-Location requires 3 hyperbolas
- 3D-Location requires 4 hyperboloids

Measurement Results

TDOA Outdoor – No Multipath

Raw Data

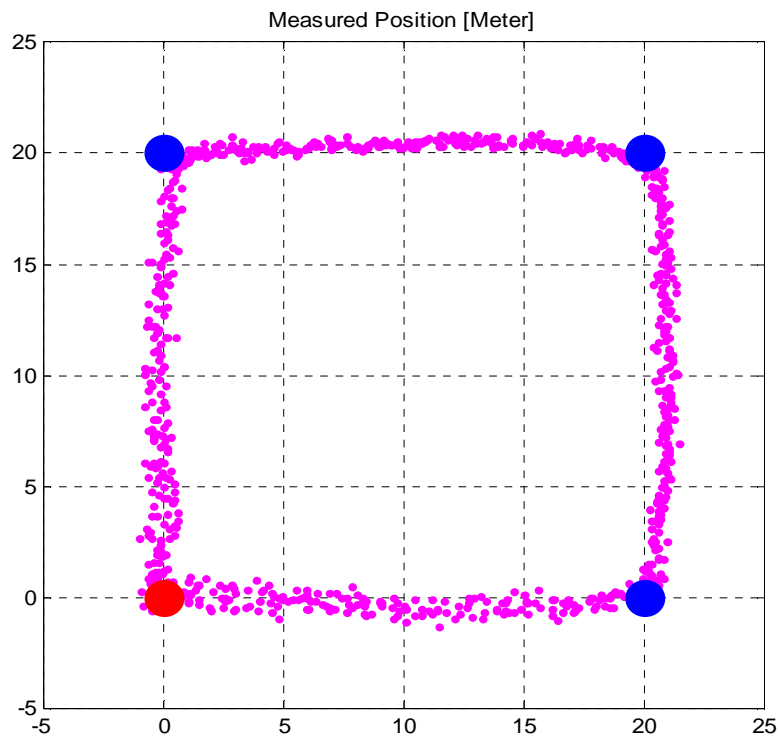

Accuracy: +/- 0.5m

Moving Average (21)

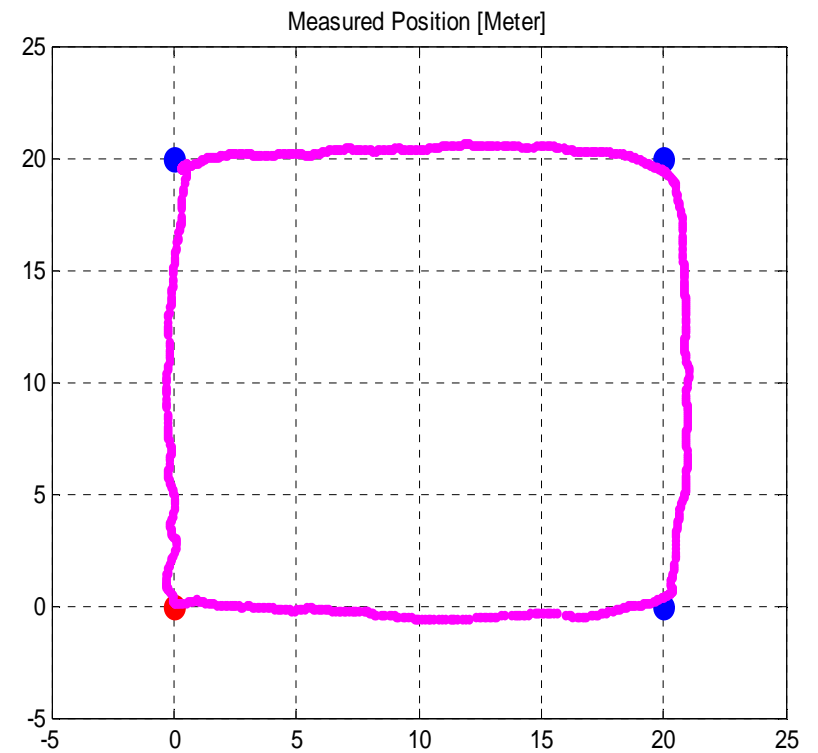

Accuracy in cm-range

Measurement Results

TDOA Indoor - Setup

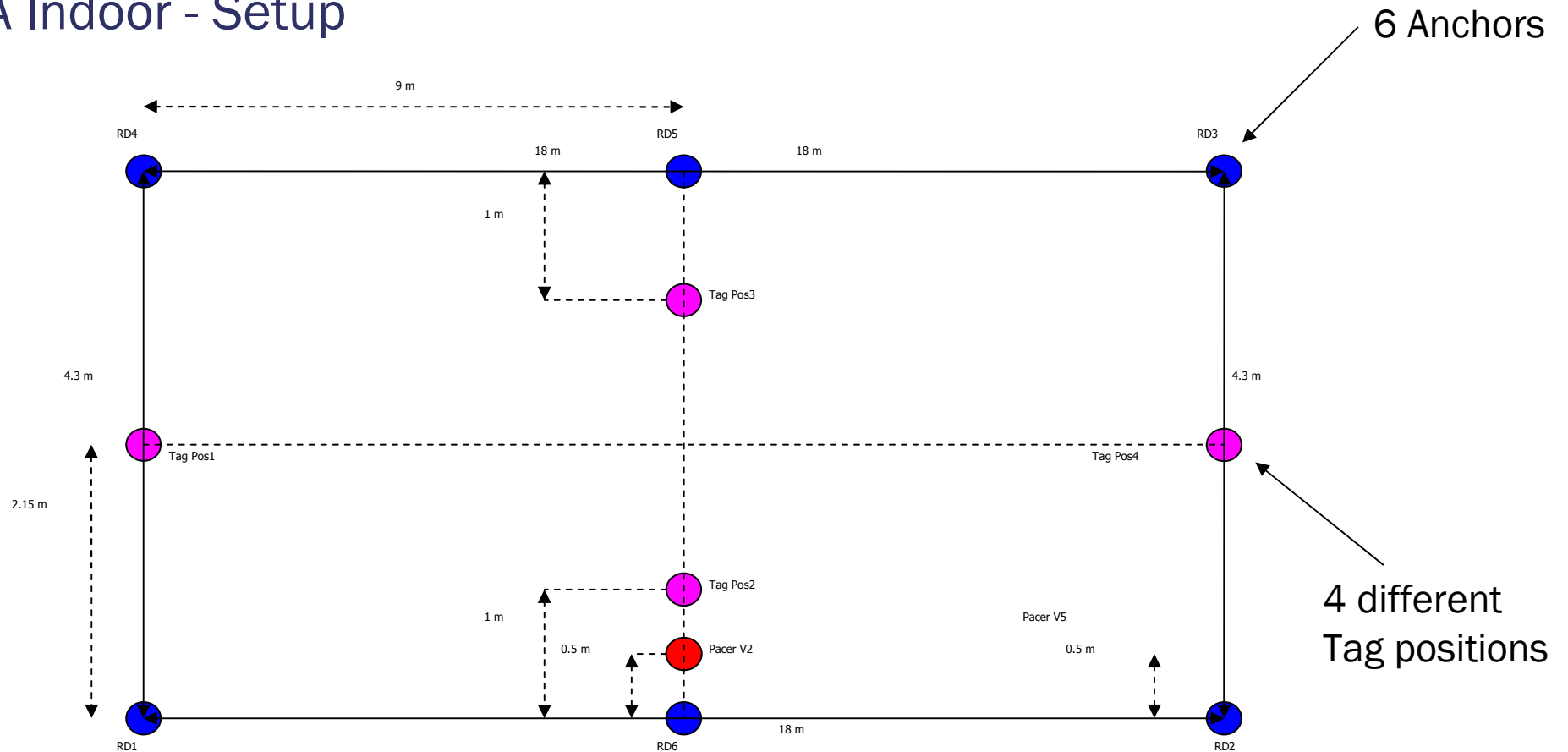

Measurement Results

TDOA Indoor – Hyperbolas & Multipath

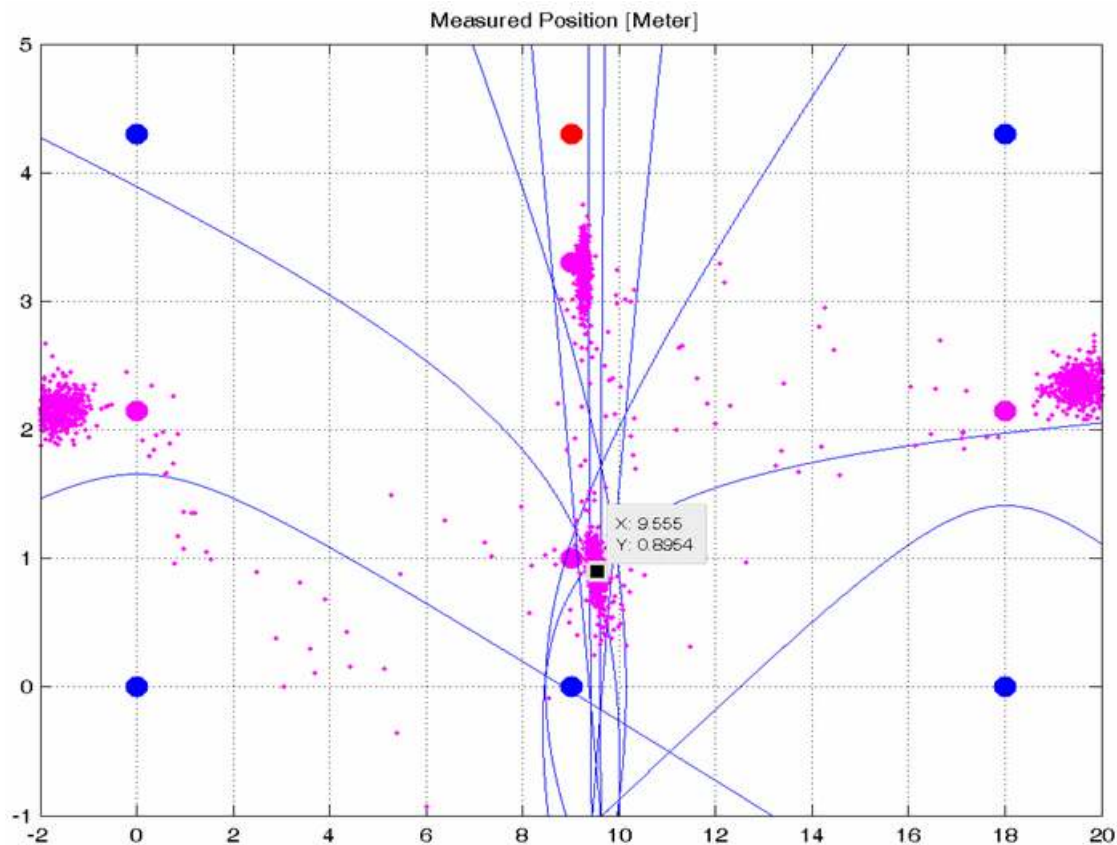

- 5 Anchors
= 10 TDOA pairs
= 10 hyperbolas
1-2, 1-3, 1-4, 1-5
2-3, 2-4, 2-5
3-4, 3-5
4-5
- Blue:
All 10 hyperbolas of location
(9.555, 0.8964)
- Some multi-path-affected
hyperbolas cause biased
locations
- Accuracy can be enhanced
by intelligent Multipath
Mitigation Methods

Improving accuracy

- Filtering
 - Raw data can be very noisy
 - Is possible and can be helpful on different levels of processing and abstraction

- Antenna Diversity
 - Can help to reduce impact of multi-path
 - Easy utilization in TOA systems:
The first (shorter) TOA reading is the better one

- Multipath Mitigation Techniques
 - Software Algorithms for location accuracy improvement
 - Several technologies available
 - Statistically
 - Geometrically
 - Redundancy, ...

For more information...

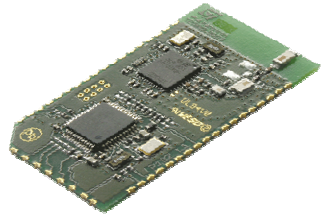

Please check
Proceeding Papers



Thank You!

Contact: Albrecht Rommel, Rainer Hach
Nanotron Technologies GmbH
Alt-Moabit 60
10555 Berlin
Germany

Tel.: +49 (0)30 399954-0

e-mail: a.rommel@nanotron.com
r.hach@nanotron.com

the leader in loss protection

www.nanotron.com